

# DIGITAL RADIUS GAGES



2188-55



2188-323



2188-143



2188-233

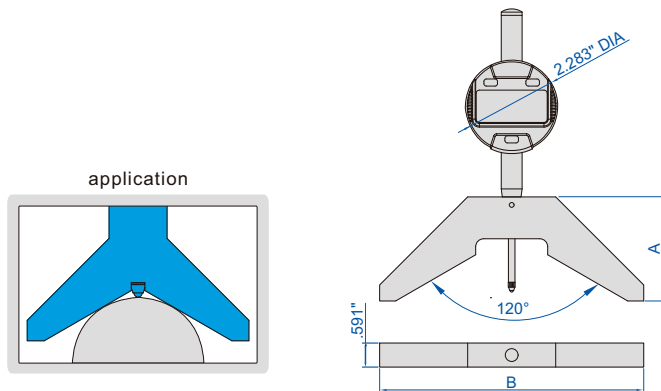

2188-P143

setting standard application



- Measure radius of external arc, arc angle of measured surface should be larger than 60°
- Display radius value, no need to calculate
- Button function: on/off, zero, data preset, inch/mm
- Keep preset data in memory after restart
- CR2032 battery, automatic power off
- Data output
- Stainless steel base
- Optional accessory: setting standards, data output cable (part no. 7315-50M, 7302-40M)

## Setting standards

Part No.	Setting standards	Remark
4110-10D00	setting standard for 2188-55	included
2188-P143	setting standard for 2188-143	optional
2188-P233	setting standard for 2188-233	optional
2188-P323	setting standard for 2188-323	optional

Part No.	Range(radius)	Resolution	Accuracy	A	B
2188-55	.16-2.09"/4-53mm	.0005"/0.01mm	±.001"	1.575"	2.559"
2188-143	1.89-5.63"/48-143mm	.0005"/0.01mm	±.0015"	2.559"	6.496"
2188-233	5.43-9.17"/138-233mm	.0005"/0.01mm	±.0015"	3.346"	10.039"
2188-323	8.98-12.72"/228-323mm	.0005"/0.01mm	±.002"	3.740"	13.582"